

Understanding and Using

Reflective Insulation,  
Radiant Barriers  
And  
Radiation Control  
Coatings

Compiled by

***RIMA*** *International*  
Reflective Insulation Manufacturers Association International

Second Edition May 2002

*Second Edition Copyright© May 2002*

**Reflective Insulation Manufacturers Association International (RIMA-I)**

14005 W. 147<sup>th</sup> Street, Olathe, KS 66062

Phone: 800-279-4123 ● Fax 913-839-8882

The Reflective Insulation Manufacturers Association International (RIMA-I), its members, and/or agents, make no guarantee as to, and assume no responsibility for, the correctness, sufficiency or completeness of the information contained herein. The information provided herein is intended to be a guide to the concept and applications of reflective insulation, radiant barriers and interior radiation control coatings.

# TABLE OF CONTENTS

<b>1. ABOUT RIMA INTERNATIONAL</b> .....	<b>1</b>
<b>2. INTRODUCTION</b> .....	<b>1</b>
<b>3. OBJECTIVES</b> .....	<b>1</b>
<b>4. FUNDAMENTALS OF HEAT TRANSFER</b> .....	<b>2</b>
4.1 Conduction	
4.2 Convection	
4.3 Radiation	
<b>5. THE NEED FOR INSULATION</b> .....	<b>5</b>
<b>6. REFLECTIVE INSULATION</b> .....	<b>6</b>
6.1 Concept of Reflective Insulation .....	6
6.2 Understanding a Reflective Insulation System .....	7
6.3 Types of Reflective Insulation Materials.....	7
6.4 Applications for Reflective Insulation Materials.....	7
6.5 Installing Reflective Insulation Systems .....	9
<b>7. RADIANT BARRIERS</b> .....	<b>9</b>
7.1 Physics of Radiant Barriers .....	9
7.2 Radiant Barrier Systems (RBS).....	10
7.3 Types of Radiant Barrier Material.....	10
7.4 Installing Radiant Barriers.....	10
7.4.1 Attics.....	10
7.4.2 Walls.....	11
7.4.3 Floors.....	11
<b>8. INTERIOR RADIATION CONTROL COATINGS (IRCC)</b> .....	<b>14</b>
8.1 Definition of an IRCC.....	14
8.2 Physics on an IRCC .....	14
8.3 Definition on an Interior Radiation Control Coatings (IRCC).....	14
8.4 Advantages of an IRCC .....	14
8.5 Installation Methods for an IRCC.....	14
8.6 Typical Installations of Interior Radiation Control Coatings (IRCC).....	15
8.6.1 Under Roof.....	15
8.6.2 Interior Side Walls .....	15
8.6.3 Exterior Side Walls .....	15
8.6.4 Other Possible Uses – Construction .....	15
8.7 Other Possible Uses of an IRCC .....	16
<b>9. GLOSSARY OF TERMS</b> .....	<b>16</b>
<b>10. REFERENCES</b> .....	<b>17</b>
10.1 Reviews .....	17
10.2 Technical Papers.....	17
10.3 Documents.....	19
10.3.1 ASHRAE Handbook .....	19
10.3.2 Federal Trade Commission .....	19
10.3.3 International Conference of Building Officials (ICBO) .....	19
10.3.4 U.S. Department of Energy.....	19
10.4 ASTM Standards .....	20
<b>11. APPENDIX – INTRODUCTORY COMMENTS ON ESTIMATING THERMAL RESISTANCES FOR REFLECTIVE INSULATION SYSTEMS</b> .....	<b>21</b>

---

## **1. ABOUT RIMA INTERNATIONAL**

The Reflective Insulation Manufacturers Association International (RIMA-I) is the only trade association representing the reflective insulation, radiant barrier and radiation control coatings industries. RIMA-I activities are guided by an active board of industry members that participate on national and local levels of building code organizations and governmental agencies.

RIMA-I's objective is to further the understanding and acceptance of reflective insulation, radiation control coatings, and radiant barriers. Toward this, RIMA-I members have contributed many articles and information that have appeared in magazines and newsletters such as:

*Builder, Journal of Light Construction, Popular Mechanics, Popular Science, Architecture, RSI, Energy Design Update, Contractor's Guide, Practical Homeowner, Rural Builder, Metal Magazine, Frame Builder NEWS, Metal Construction News, and Metal Architecture.*

RIMA-I has also contributed technical papers to various conferences and workshops sponsored by the Department of Energy, ASHRAE, TVA, ASTM, and Oak Ridge National Laboratory. RIMA-I members meet twice a year in conjunction with the ASTM C-16 Committee meetings to discuss current technical issues and establish standards that promote the best use of reflective insulation, radiation control coatings, and radiant barrier products. RIMA-I's members come from a variety of backgrounds including engineers, scientists, manufacturers, marketers, and academicians.

The RIMA-I Handbook aims to provide a simple yet comprehensive guide elaborating on the fundamentals of heat transfer and the concept of reflective insulation, radiant barriers and interior radiation control coatings (IRCCs').

## **2. INTRODUCTION**

The key to maintaining a comfortable temperature in a building is to reduce the heat transfer out of the building in the winter and reduce heat transfer into the building in the summer.

Heat is transmitted across confined air spaces by radiation, convection, and conduction. The goal is to reduce heating and cooling loads. Reflective insulation, radiant control coatings, and radiant barriers are products that perform this function by reducing radiant heat transfer thereby reducing the heating and cooling requirements.

## **3. OBJECTIVES**

- Discuss heat transfer, with an emphasis on radiant heat transfer.
- Explain the underlying principles of reflective insulation, radiant barriers and interior radiation control coatings.
- Clarify the differences between these three reflective technologies and illustrate applications best suited to each product.
- Provide a working knowledge of the effective use of reflective insulation, radiant barriers and interior radiation control coatings.

---

The handbook does not intend to be a definitive source, but will cover some basic information. There are a large number of excellent authoritative publications about reflective technologies and products. They are listed in section 10, References, and are recommended for additional information and guidance. Our purpose in this section is to inform in an easily understandable way, the virtues of the reflective products represented by RIMA-I members.

## **4. FUNDAMENTALS OF HEAT TRANSFER**

Heat flows from a hot or warm medium to a cold medium in three ways:

- By radiation from a warm surface to a cooler surface through an air space
- By conduction through solid or fluid materials
- By convection, which involves the physical movement of air

### **4.1 Conduction**

Conduction is the direct flow of heat through a material resulting from physical contact. The transfer of heat by conduction is caused by molecular motion in which molecules transfer their energy to adjoining molecules and increase their temperature.

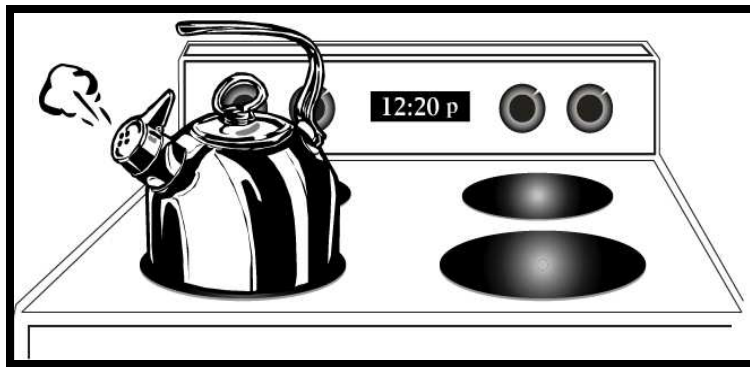

A typical example of conduction would be the heat transferred from hot coffee, through the cup, to the hand holding the cup. Another example, as shown above, the contents of the kettle boils from heat transferred from the burner to the kettle. Also, a poker becomes hot from contact with hot coals.

Heat transfer by conduction is governed by a fundamental equation known as Fourier's Law.

$$(\text{Rate of Heat Flow}) = -k \times (\text{Area}) \times (\text{Temperature Gradient})$$

The factor  $k$  is called thermal conductivity or in the case of many insulation materials "apparent thermal conductivity". This property is characteristic of the material and it varies with temperature, density (degree of compaction), and composition. Some typical thermal conductivity and thermal resistivity data are given in the following table for the purpose of comparison.

Material	k-value <sup>1,2</sup>	R/inch <sup>3</sup>
Sawdust	0.36	2.8
Wood Shavings	0.41	2.4
INSULATION		
Std. Fiberglass Batt	0.313	3.2
High Performance Fiberglass Batt	0.263	3.8
Loose-Fill Fiberglass	0.400	2.5
Loose-Fill Rock Wool	0.357	2.8
Loose-Fill Cellulose	0.270	3.7
Expanded Polystyrene	0.263	3.8
Extruded Polystyrene	0.200	5.0
GASES		
Air	0.181	5.5
Carbon Dioxide	0.115	8.7
Helium	1.04	0.96
Methane	0.237	4.2
LIQUIDS		
Ethylene Glycol	1.80	0.56
Gasoline	0.94	1.06
Water	4.19	0.24
METALS		
Aluminum	1890	0.00053
Copper	2760	0.00036
Iron	555	0.0018
Lead	240	0.0042
MISCELLANEOUS BUILDING MATERIALS		
Acoustical Tile	0.40	2.5
Asphalt	5.2	0.19
Concrete (140 lb/ft <sup>3</sup> )	12.0	0.08
Cotton (6 lb/ft <sup>3</sup> )	0.30	3.3
Window glass	6.10	0.16
Soil	4-20	0.25-0.05
Fir	0.76	1.3
Oak	1.18	0.85
Yellow Pine	1.04	0.96
Plywood	0.83	1.2
<sup>(1)</sup> Values shown are at 75°F (approximately 300K) <sup>(2)</sup> Nominal values in Btu·in./ft <sup>2</sup> ·hr·°F <sup>(3)</sup> Thermal resistivities in ft <sup>2</sup> ·hr·°F/Btu·in.		

## 4.2 Convection

Convection in buildings is the transfer of heat caused by the movement of heated air. In a building space, warm air rises and cold air settles to create a convection loop and is termed free convection. Convection can also be caused mechanically, (termed forced convection), by a fan or by wind.

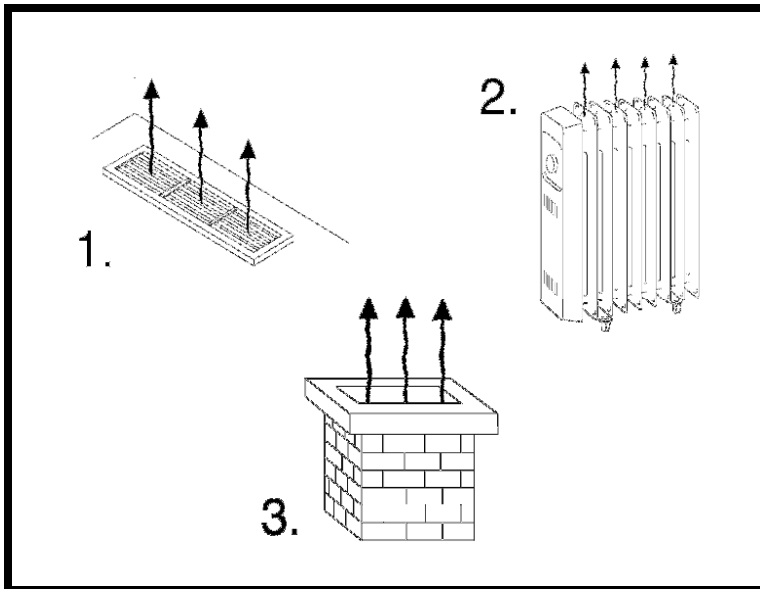

Typical examples of heat transfer through convection:

1. Warm air rising from register. (forced convection)
2. Warm air rising from all surfaces of radiator, (after air in contact with radiator has been heated by conduction).
3. Warm air rising from chimney. (free convection)

In the flow of heat through a solid body to air, it was observed that the passage of heat into the air was not accomplished solely through conduction. Instead, it occurred partly by radiation and partly by free convection. A temperature difference existed between the hot solid and the average temperature of the air. In this case, the resistance to heat transfer cannot be computed using the thermal conductivity of air alone. Instead, the resistance has to be determined experimentally by measuring the surface temperature of the solid, the temperature of air, and the heat transferred from the solid to air. The resistance computed is the combined resistance of conduction, free convection, and radiation. This resistance, denoted by the letter "R", has the units of  $(\text{hr}\cdot\text{ft}^2\cdot\text{F}/\text{Btu})$  and is commonly used to indicate the thermal characteristics of insulation materials.

### 4.3 Radiation

Radiation is the transfer of heat (infra-red radiant energy) from a hot surface to a cold surface through air or vacuum. All surfaces including a radiator, stove, a ceiling or roof and ordinary insulation radiate to different degrees. The radiant heat is invisible and has no temperature, just energy. When this energy strikes another surface, it is absorbed and increases the temperature of that surface. This concept can be understood with the following example: On a bright sunny day, radiant heat from the sun travels through a car's window, strikes the steering wheel and is absorbed, causing it to rise in temperature.

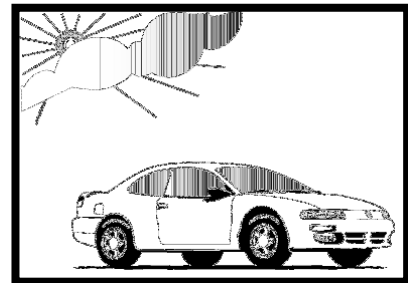

Radiation from the sun strikes the outer surfaces of walls and roofs and is absorbed causing the surface to heat up. This heat flows from the outer wall to the inner wall through conduction which is then radiated again, through the air spaces in the building, to other surfaces within the building.

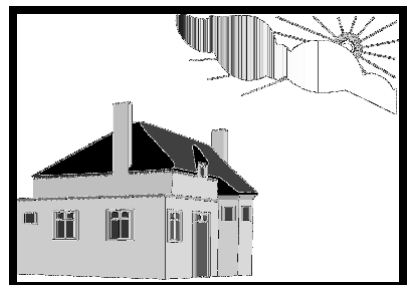

There are two terms commonly encountered while discussing radiant heat transfer:

1. **Emittance** (or emissivity), refers to the ability of a material's surface to emit radiant energy. All materials have emissivities ranging from zero to one. The lower the emittance of a material, the lower the heat (infra-red radiant energy) radiated from its surface. Aluminum foil has a very low emittance, which explains its use in reflective insulation and radiant barriers.
2. **Reflectance** (or reflectivity) refers to the fraction of incoming radiant energy that is reflected from the surface. Reflectivity and emissivity are related and a low emittance is indicative of a highly reflective surface. For example, aluminum with an emissivity of 0.03 has a reflectance of 0.97.

The emittance of various surfaces is listed in the following table<sup>2</sup>.

<b>Material Surface</b>	<b>Emittance</b>
Asphalt	0.90-0.98
Aluminum foil	0.03-0.05
Brick	0.93
Concrete	0.85-0.95
Glass	0.95
Fiberglass/Cellulose	0.8-0.90
Limestone	0.36-0.90
Marble	0.93
Paint: white lacquer	0.80
Paint: white enamel	0.91
Paint: black lacquer	0.80
Paint: black enamel	0.91
Paper	0.92
Plaster	0.91
Silver	0.02
Steel (mild)	0.12
Wood	0.90

## **5. THE NEED FOR INSULATION**

When installed correctly, insulation reduces the heat transfer through the envelope of a building. Whenever there is a temperature difference, heat flows naturally from a warmer space to a cooler space. To maintain comfort in winter, the heat lost must be replaced by the heating system; and in summer, the heat gained must be removed by the cooling system. Statistics show that 50% to 70% of the energy used in the average home in the United States and Canada is for heating and cooling. It makes sense to use thermal insulation to reduce this energy consumption, while increasing comfort and saving money. Naturally, less consumption of fossil fuels and the energy produced from them relieves the burden our ecosystem must bear.

To summarize, insulating the envelope of a building's conditioned space yields these key benefits:



- 
1. Provides a much more comfortable, productive and livable structure. In addition, the effects of moisture condensation and air movement are minimized in well-insulated buildings. This results in lower maintenance costs and increased longevity of the building structure.
  2. Reduces energy requirements, which lowers utility bills.
  3. Supports economic, environmental and energy conservation goals. This is evidenced by the numerous studies sponsored by the Department of Energy.

Heat moves through wall cavities or between roofs and attic floors by radiation, conduction, and convection. In some buildings, radiation is the dominant method of heat transfer. A reflective insulation is an effective barrier against radiant heat transfer because it reflects almost all of the infrared radiation striking its surface and emits very little of the heat conducted through it. By virtue of its impermeable surface, reflective insulation also reduces convective heat transfer. Mass insulation like fiberglass or foam board primarily slows conductive heat transfer, and to a smaller extent, convective heat transfer. However, mass insulation is not as effective against infrared radiation, actually absorbing it rather than reflecting or blocking it.

## **6. REFLECTIVE INSULATION**

**Definition:** Thermal insulation consisting of one or more low emittance surfaces, bounding one or more enclosed air spaces.

### **6.1 Concept of Reflective Insulation**

Standard types of insulation, such as fiberglass, foam, and cellulose primarily reduce heat transfer by trapping air or some type of a gas. Thus, these products or technologies reduce convection as a primary method of reducing heat transfer. They are not as effective in reducing radiant heat transfer, which is often a primary mode of heat transfer in a building envelope, in fact, these products, *like most building materials*, have very high radiant transfer rates. In other words the surfaces of standard types of insulation are good radiators of heat.

Reflective insulation uses layers of aluminum, paper, and/or plastic to trap air and thus reduce convective heat transfer. The aluminum component however is very effective in reducing radiant heat transfer. In fact, the metalized and foil materials commonly used in reflective insulation will reduce radiant heat transfer by as much as 97%.

Heat flow by radiation has been brought to the public's attention with high efficiency windows, which commonly use the term "Low E" to advertise the higher performance ratings. The "E" stands for emittance and the values range from 0 to 1, with 0 being no radiation and 1 is the highest measure of emittance or radiation. Most building materials, including fiberglass, foam and cellulose have surface emittances or "E" values in excess of 0.70. Reflective insulations typically have "E" values of 0.03 (again, the lower the better). Therefore, reflective insulation is superior to other types of insulating materials in reducing radiant heat. The term reflective, in reflective insulation, is in some ways a misnomer, because aluminum either works by reflecting heat (reflectance of 0.97) or by *not radiating heat* (emittance of 0.03). Whether stated as reflectivity or emissivity, the performance (heat transfer) is the same. When reflective insulation is installed in building cavities, it traps air (like other insulation materials) and therefore reduces heat flow by convection, thus addressing all three modes of heat transfer.

---

In all cases, the reflective material must be adjacent to an air space. Aluminum, when sandwiched between two pieces of plywood for example, will conduct heat at a high rate.

All insulation products including reflective insulation are measured by R-values, whereby the “R” means resistance to heat flow. The higher the R-value, the greater the insulating or thermal performance of the material.

Reflective insulation is a non-toxic, user and building owner safe, and environmentally safe building material. In addition, the products are typically recyclable and thus can be termed a Green Building Material.

Another benefit is that the reflective insulation can also serve as a high performance and thus effective vapor barrier.

## **6.2 Understanding a Reflective Insulation System (RIS)**

Layers of aluminum or a low emittance material and enclosed air spaces, which in turn provide highly reflective or low emittance cavities adjacent to a heated region, typically form a reflective insulation system. Some reflective insulation systems also use other layers of materials such as paper or plastic to form additional enclosed air spaces. The performance of the system is determined by the emittance of the material(s), the lower the better, and the size of the enclosed air spaces. The smaller the air space, the less heat will transfer by convection. Therefore, to lessen heat flow by convection, a reflective insulation, with its multiple layers of aluminum and enclosed air space, is positioned in a building cavity (stud wall, furred-out masonry wall, floor joist, ceiling joist, etc.) to divide the larger cavity (3/4” furring, 2” x 4”, 2” x 6”, etc.) into smaller air spaces. These smaller trapped air spaces reduce convective heat flow.

Reflective insulation differs from conventional mass insulation in the following:

1. Reflective insulation has very low emittance values “E-values” (typically 0.03 compared to 0.90 for most insulation) thus significantly reduces heat transfer by radiation;
2. A reflective insulation does not have significant mass to absorb and retain heat;
3. Reflective insulation has lower moisture transfer and absorption rates, in most cases;
4. Reflective insulation traps air with layers of aluminum, paper and/or plastic as opposed to mass insulation which uses fibers of glass, particles of foam, or ground up paper;
5. Reflective insulation does not irritate the skin, eyes, or throat and contain no substances which will out-gas;
6. The change in thermal performance due to compaction or moisture absorption, a common concern with mass insulation, is not an issue with reflective insulation.

## **6.3 Types of Reflective Insulation Materials**

Reflective insulation has been used effectively for decades and is available throughout the world. The following are the major types of reflective insulation currently available:

1. Layer or layers of aluminum foil separated by a layer or layers of plastic bubbles or a foam material;
2. Multiple layers of aluminum, kraft paper, and/or plastic with internal expanders and flanges at the edge for easy installation;

3. Single layer of aluminum foil laminated to a kraft paper or plastic material when encapsulated with an adjacent air space.

#### 6.4 Applications for Reflective Insulation Materials

Reflective insulation materials are designed for installation between, over, or under framing members and as a result, are applicable to walls, floors, and ceilings. Applications for reflective insulation extend to many commercial, agricultural and industrial uses, such as panelized wood roofs, pre-engineered buildings, pole barns and other wood framed structures. A few representative applications are listed below:

- **Residential Construction, New and Retrofit**  
Walls, basements, floors, ceilings, roofs, and crawl spaces.
- **Commercial Construction, New and Retrofit**  
Walls, floors, basements, ceilings, roofs, and crawl spaces.
- **Manufactured Housing Construction, New and Retrofit**  
Walls, floors, roofs, and crawl spaces.
- **Other Uses, New and Retrofit**  
Water heater covers, cold storage units, poultry, and livestock buildings, equipment sheds, pipe insulation and recreational vehicles.

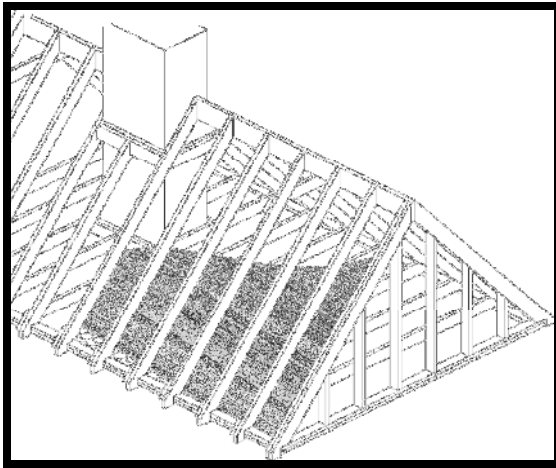

**A Typical Attic  
Installation for  
Reflective Insulation**

#### Reflective Insulation In A Typical Basement Installation

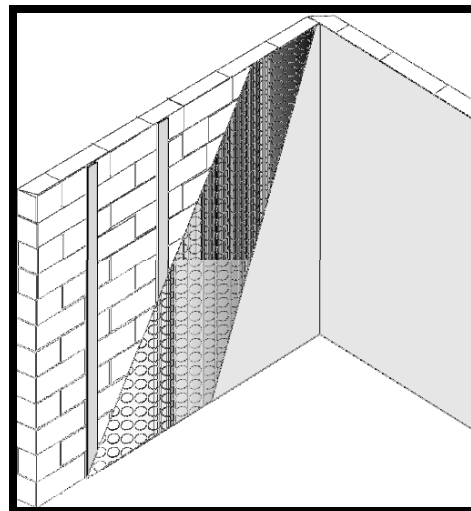
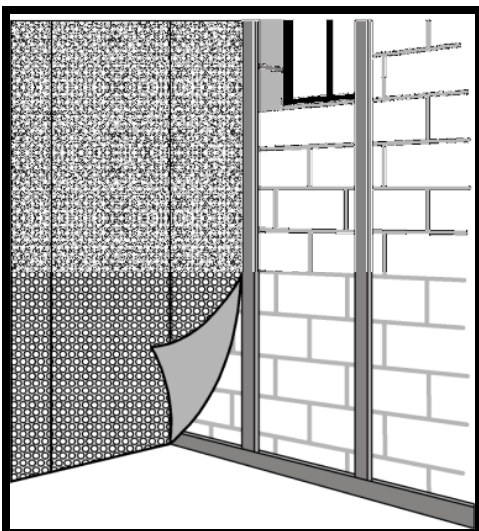

## 6.5 Installing Reflective Insulation Systems

Reflective insulation products incorporate trapped air spaces as part of the system. These air spaces, which may be layered or closed-cell, can be included in the system either when the product is manufactured or while it is being installed. In either case, the advertised performance of the insulation requires that these air spaces be present after the product is installed. The labeled R-values will not be achieved if the product is not installed according to the instructions of the manufacturer.

The thermal performance of the reflective system varies with the size and number of enclosed reflective spaces within the building cavity. Most reflective systems range from one to five enclosed air spaces.

**Air spaces in typical Reflective Insulation System**

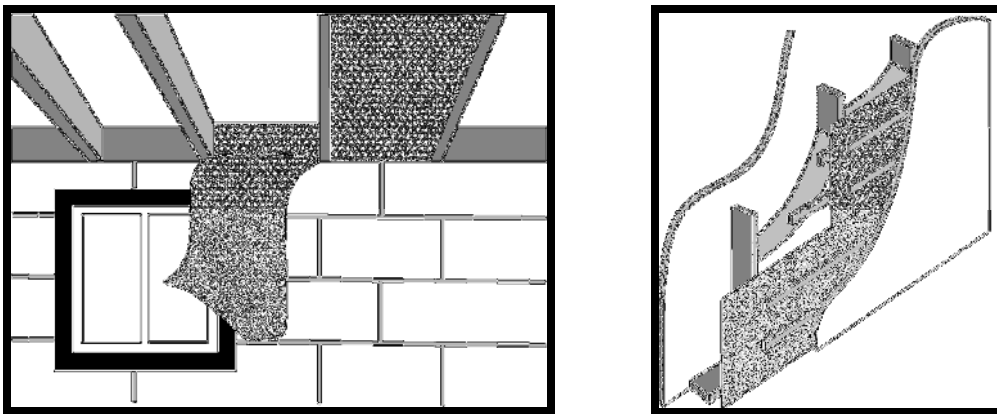

There are other beneficial considerations for using reflective insulation. Generally, these products have a very low water vapor and air permeance. When installed properly, with joints taped securely, reflective insulation materials are efficient vapor retarders and an effective barrier to air and radon gas.

Since reflective insulation materials are effective vapor retarders, care should be taken to ensure that they are installed correctly within the structure. Correct installation depends on the climatic conditions and moisture sources involved. An appropriate installation ensures that all joints and seams are butted against each other and taped, or overlapped and taped. This will reduce the possibility of moisture condensation within the cavity and improve performance.

---

## **7. RADIANT BARRIERS**

**Definition:** The generally accepted definition of a radiant barrier system specifies that the reflective material face an open air space. The idea is that a radiant barrier facing an enclosed air space is a “reflective insulation” with a measurable R- value.

### **7.1 Physics of Radiant Barriers**

A “radiant barrier” is a reflective/low-emittance surface as defined by ASTM where the emittance is 0.10 or less on or near a building component, that intercepts the flow of radiant energy to and from the building component.

The aluminum foil shields that are commonly inserted behind radiators in older houses are radiant barriers, blocking radiant heat transfer from the radiator to the exterior wall.

It should be clearly understood that although a radiant barrier reduces heat loss and gain through the building envelope because it is installed in vented cavities (like attics), it is not an insulation material per se and has no inherent R-value.

### **7.2 Radiant Barrier Systems (RBS)**

A “radiant barrier system” (RBS) is a building section that includes a radiant barrier facing an air space. An attic with a radiant barrier on top of the mass insulation on the floor, or under the roof is an RBS. A vent skin wall with a radiant barrier facing the vented air space is also an RBS. (See diagram on page 14.)

The distinction between a radiant barrier “material” and radiant barrier “system” is not merely academic. In an attic, the effectiveness of a radiant barrier is significantly affected by the amount of attic ventilation. A vented attic with a radiant barrier is a very different system from an unvented attic with the same radiant barrier.

### **7.3 Types of Radiant Barrier Material**

Several types of radiant barrier materials are available. Although they all have similar surface properties (and consequently similar performance), variations in materials and construction result in significant differences with respect to strength, durability, flammability and water vapor permeability.

Most products available commercially fall into three major categories:

1. Aluminum Foil Laminates - foil laminated to kraft paper, plastic films, or to OSB/plywood roof sheathing
2. Aluminized Plastic Films - a thin layer of aluminum particles deposited on film through vacuum process

### **7.4 Installing Radiant Barriers**

#### **7.4.1 Attics**

The most common location for a radiant barrier system is in attics. Three basic configurations are used:

### 1. Rafter/truss installation

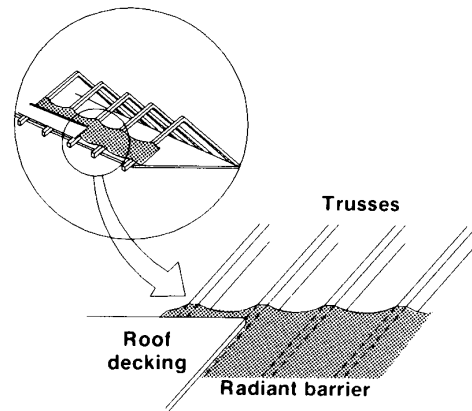
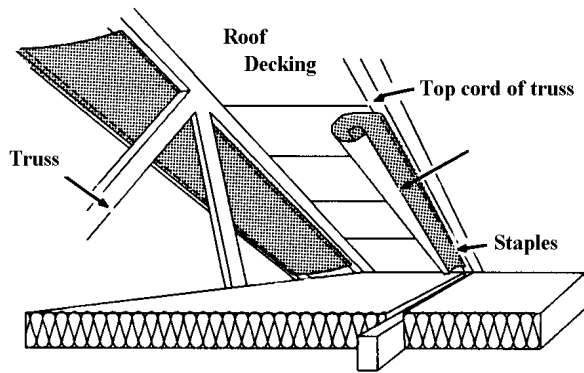

**A radiant barrier can be draped over the trusses with the foil facing down.**

### 2. Under, or pre-laminated to, roof sheathing

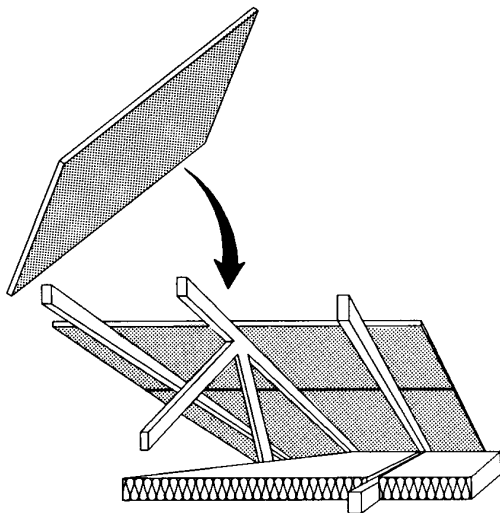

### 3. Horizontal installation (directly above ceiling and/or ceiling insulation)

RIMA-I acknowledges the placement of a radiant barrier on top of mass insulation in attic spaces subject to the following conditions:

- The mass insulation and ceiling building materials should be checked for any evidence of moisture accumulation. Any existing moisture problem should be corrected before installing the radiant barrier.
- Radiant barriers used for this application must have a water vapor transmission per of at least five (5), as measured by ASTM E-96.
- Installation should be accomplished by laying the radiant barrier materials on top of the attic insulation without stapling or taping, so that it has very loose contact with the material below.
- Radiant barriers for this application should meet a Class A, Class 1 flame spread and smoke development rating as determined by ASTM E-84.
- The potential for contamination of the top surface by dust or dirt must be considered in specific applications where applicable.
- As with all building materials, local building codes should be considered.

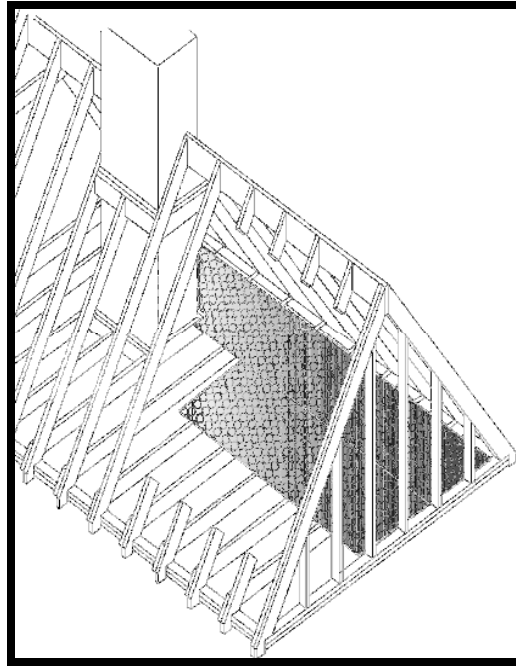

As noted before, a vented attic with a radiant barrier is a very different system from an unvented attic with the same radiant barrier. Common types of attic ventilation are:

- Soffit to ridge
- Soffit to gable
- Soffit to soffit
- Gable to gable
- 

Most codes require at least a 1 to 300 ventilation rate. What this means is that for every 300 square feet of floor space, there should be one square foot of free vent area.

#### **7.4.2 Walls**

A very effective technique for walls is a vented skin wall using a radiant barrier. Furring strips are used to separate the outer skin from the internal structural wall. The wall is wrapped with a radiant barrier facing the vented air space. Vents are used at top and bottom to allow the heated air to rise naturally to the attic, where it is vented out through the roof vents.

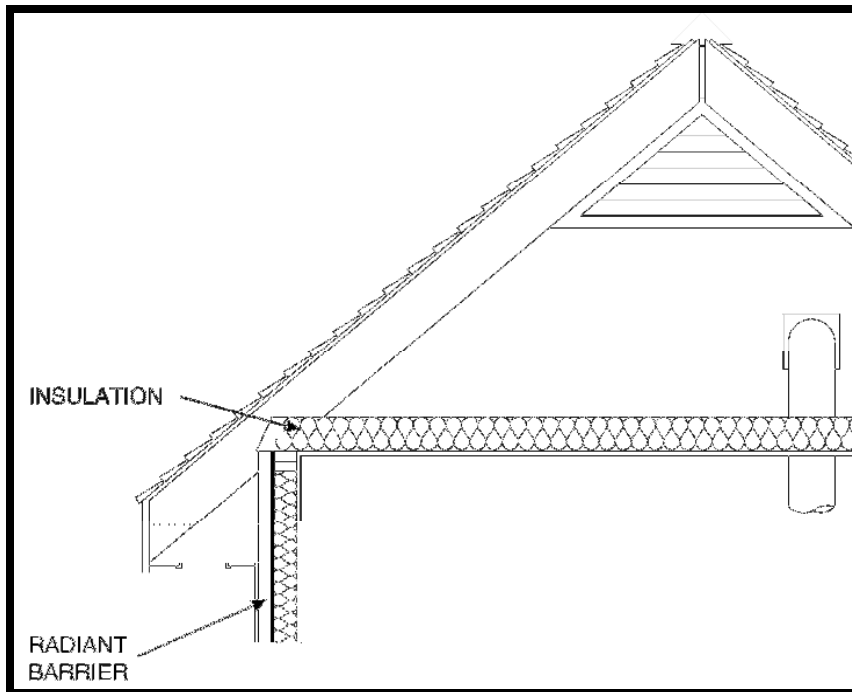

**TECHNICAL NOTE:** Radiant barriers which are non-perforated are vapor barriers. Care should be exercised with placement!

### 7.4.3 Floors

Radiant barriers can also be used in floor systems above unheated basements and crawl spaces. The radiant barrier is either stapled to the underside of floor joists, creating a single reflective air space, or between the joists, followed by some type of sheathing, creating two separate reflective air spaces as shown below.

Radiant barriers are an ideal choice for this application because, in addition to their excellent thermal properties, they are also vapor barriers that prevent ground moisture from migrating into the living space above.



---

## **8. INTERIOR RADIATION CONTROL COATINGS (IRCC)**

### **8.1 Definition of an IRCC**

As characterized by ASTM, an Interior Radiation Control Coating is a non-thickness dependent, low emittance coating. When applied to non-porous building materials such as plywood, OSB, metal siding or plasterboard, according to the manufacturer's installation instruction, it lowers the normal surface emittance of these materials to 0.24 or lower.

### **8.2 Physics of an IRCC**

An IRCC works by changing the emittance of the surface where it is applied. Building products, such as wood, brick, painted surfaces and plasterboard exhibit high emissivities (0.7 - 0.95). When heated above the temperature of adjacent surfaces, they radiate most of their heat energy to cooler surfaces. An IRCC works by lowering their surface emittance to 0.24 or lower, lessening their ability to radiate heat.

### **8.3 Definition of an Interior Radiation Control System (IRCCS)**

A building construction consisting of a low emittance (normally 0.25 or less) surface bounded by an open air space. An IRCCS is used for the sole purpose of limiting heat transfer by radiation and is not specifically intended to reduce heat transfer by convection or conduction. (ASTM C 1321, section 3.2.3)

Thus, an IRCCS is similar to a Radiant Barrier System (RBS) but is somewhat less efficient due to its higher emissivity and is comprised of a coating on a building surface, not a foil or film product.

### **8.4 Advantages of an IRCC**

An IRCC is normally applied using airless spray equipment, resulting in very low labor costs and greatly reduced installation times. Also, a water based IRCC can be safely installed in existing structures where the costs of installing foil or film products may be prohibitive or impractical. An IRCC may also be used in many manufactured products (such as infrared heat reflectors of automotive parts) where it is impractical to adhere foil or film radiant barriers.

### **8.5 Installation methods for an IRCC**

Since an IRCC is a paint product, spray painting, either air atomization or airless is the most effective method of installation. Where spray painting is not practical. An IRCC may be applied using a low nap roller. Brush painting is usually impractical since these coatings are very low viscosity and not formulated for brush application.

The IRCC may be applied to a building surface already in place (such as the underside of an installed roof deck or the inside of a wall) or it may be applied to a building component before it is installed (such as roof decking painted while laying on the ground before it is lifted into place. Regardless when a building component is painted with and IRCC, it is imperative that after installation the surface painted with the IRCC face a minimum of a 2" air space.

## 8.6 Typical installations of an IRCC

### 8.6.1 Under Roof

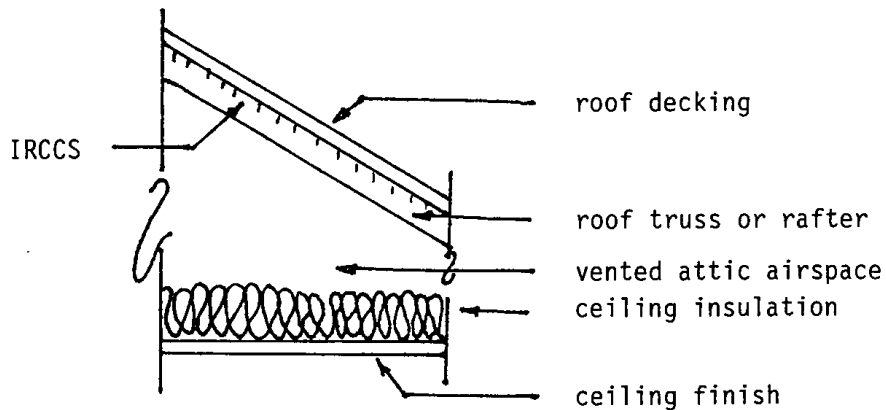
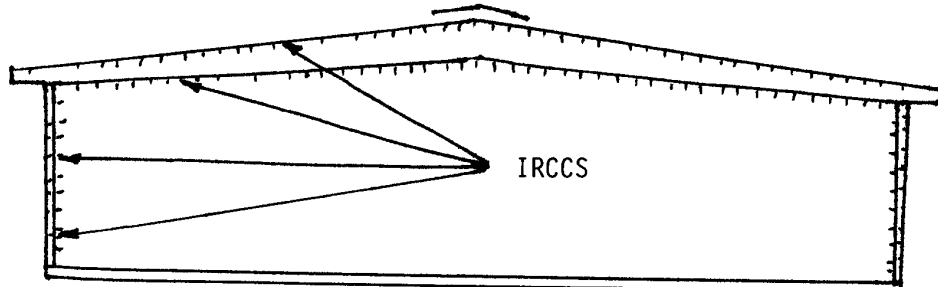

### 8.6.2 Interior Side Walls

IRCC materials can be installed on the interior side of walls in buildings.

### 8.6.3 Exterior Side Walls

IRCC materials can be installed on the exterior side of walls and covered with exterior coverings.

### 8.6.4 Other Possible Uses - Construction

An IRCC is a paint product and, therefore, it can be used on almost any solid surface where paint can be applied and where radiant heat transfer is a problem. An example would be painting the inside of a boiler room to retain heat that might make adjacent areas uncomfortable. Even painting the boiler itself might make it operate more efficiently. Freestanding heat shields in welding bays or at foundries can be painted with an IRCC. Exterior roof surfaces may also be painted with an IRCC to repel summer heat and lower radiation losses in the winter.

---

## 8.7 Other Possible Uses of an IRCC

IRCC technology has many applications in manufacturing and industry. It is used in the automotive industry to keep temperature sensitive parts and automotive interiors cool. It is used in the lighting industry to make plastic reflectors for heat lamps and radiant heating devices. It is used as a heat reflecting surface in industrial ovens. It is used on high temperature process piping and storage tanks in chemical plants to lessen heat loss. Any process or device that is temperature sensitive to infrared heat problems or uses reflected heat in its operation may be a candidate for IRCC technology.

### **GLOSSARY OF TERMS**

**Conduction:** Conduction is the direct flow of heat through a material resulting from physical contact. The transfer of heat by conduction is caused by molecular motion in which molecules transfer their energy to adjoining molecules and increase their temperature.

**Convection:** Convection is the transfer of heat in fluid or air, caused by the movement of the heated air or fluid itself. In a building space, warm air rises and cold air settles to create a convection loop and is termed free convection. Convection can also be caused mechanically by a fan and is termed forced convection.

**Emittance:** Emittance refers to the ability of the surface to emit radiant energy. Emissivity ranges from 0 to 1 and a lower value indicates a reflective surface with a low level of radiation.

**Interior Radiation Control Coating:** A non-thickness dependent, low-emittance coating.

**“R” value:** Property of an insulation material used to characterize the effectiveness of the insulation in reducing heat transfer by conduction. The higher the “R” value, the better the insulation’s ability to reduce this heat transfer.

**Radiation:** Radiation is the transfer of heat or energy from a hot surface to a cold surface through air or through a vacuum.

**Radiant Barrier:** A radiant barrier is a reflective material having a surface emittance of 0.1 or less used for the sole purpose of limiting heat transfer by radiation.

**Radiant Barrier System:** A building construction consisting of a low emittance surface (0.1 or less, usually aluminum foil) bounded by an open air space.

**Reflectance:** Reflectance refers to the fraction of incoming radiant energy that is reflected from the surface.

**Reflective Insulation System:** Reflective Insulation System is formed by a combination of low emittance surfaces and air spaces that provide reflective cavities which have low levels of radiant energy transmission.

---

## **REFERENCES**

The following list of references is selective rather than exhaustive. Technical papers, reports, sections of books, and important compliance documents have been included. Many of the papers and reports contain references that broaden the list and provide additional insight into the performance of reflective insulation and radiant barriers.

### **Reviews**

1. Gross and R.G. Miller, "Literature Review of Measurement and Predictions of Reflective Building Insulation System Performance: 1900-1989", ASHRAE Transactions 95 (2) 651-664 (1989).
2. Ned Nisson: Radiant Barriers, Principles, Practice, and Product Directory", Energy Design Update, Cutter Information Corporation, Arlington, MA (1990).

### **Technical Papers**

1. Ludwig, Adams, "Thermal Conductance of Air Spaces", ASHRAE Journal (March, 1976) pp. 37-38
2. Cook, D.W. Yarbrough, and K.E. Wilkes, "Contamination of Reflective Foils in Horizontal Applications and the Effect on Thermal Performance", ASHRAE Transactions 95 (1) (1989).
3. Andre O. Desjarlais and David W. Yarbrough, "Prediction of the Thermal Performance of Single and Multi-Airspace Reflective Insulation Materials", Insulation Materials: Testing and Applications, 2nd Volume, ASTM STP 1116, R.S. Graves and D.C. Wysocki, Editors, American Society for Testing and Materials, Philadelphia (1991).
4. Fairey, "Effect of Infrared Radiation Barriers on the Effective Thermal Resistance of Building Envelopes", Proceedings of the ASHRAE/DOE Conference on Thermal Performance of the Exterior Envelopes of Buildings II, ASHRAE Special Publication 38 (1983).
5. Philip Fairey, "The Measured, Side-by-Side Performance of Attic Radiant Barrier Systems in Hot-Humid Climates", Thermal Conductivity 19, David W. Yarbrough, Editor, Plenum Press (1988) pp. 481-496.
6. Robert Hageman and Mark P. Medera, "Energy Savings and HVAC Capacity Implications of a Low-Emissivity Interior Surface for Roof Sheathing".
7. Joy, "Improving Attic Space Insulating Values", ASHRAE Transactions 64 251 (1959).
8. Levins and M.A. Karnitz, "Cooling Energy Measurements of Unoccupied Single-Family Houses with Attics Containing Radiant Barriers", ORNL/CON-200 (1986), Oak Ridge National Laboratory, Oak Ridge, TN.

- 
9. Levins and M.A. Karnitz, "Cooling Energy Measurements of Unoccupied Single-Family Houses with Attics Containing Radiant Barriers, ORNL/CON-213 (1987), Oak Ridge National Laboratory, Oak Ridge, TN.
  10. Levins and M.A. Karnitz, "Cooling Energy Measurements of Unoccupied Single-Family Houses with Attics Containing Radiant Barriers, ORNL/CON-226 (1987), Oak Ridge National Laboratory, Oak Ridge, TN.
  11. Levins and M.A. Karnitz, "Cooling Energy Measurements of Unoccupied Single-Family Houses with Attics Containing Radiant Barriers", ORNL/CON-239 (1988), Oak Ridge National Laboratory, Oak Ridge, TN.
  12. Levins, M.A. Karnitz, and J.A. Hall, "Moisture Measurements in Single-Family Houses Containing Radiant Barriers", ORNL/CON-255 (1989), Oak Ridge National Laboratory, Oak Ridge, TN.
  13. McQuiston, S.L. Der, and S.B. Sandoval, "Thermal Simulation of Attic and Ceiling Spaces", ASHRAE Transactions 90 739-163 (1984).
  14. Pratt, "Heat Transmission in Buildings, John Wiley and Sons, Chapter 3, "The Thermal Resistance of Airspaces in Cavity Building Structures", (181) pgs. 66-98.
  15. Robinson and F.J. Powell, "The Thermal Insulating Value of Airspaces", Housing Research Paper No. 32, National Bureau of Standards Project NE-12, National Bureau of Standards, Washington, DC (1954).
  16. Robinson, L.A. Cosgrove and F.J. Powell, "Thermal Resistance of Airspaces and Fibrous Insulation Bounded by Reflective Surfaces", Building Materials and Structures Report 151, National Bureau of Standards, Washington, DC (1957).
  17. St. Regis, "Reflective Insulation and the Control of Thermal Environments", St. Regis-ACI, Diethelm & Co., LTD, Bangkok, Thailand (1969).
  18. Wilkes, "Thermal Modeling of Residential Attics with Radiant Barriers: Comparison with Laboratory and Field Data", Thermal Performance of the Exterior Envelopes of Buildings IV, ASHRAE (1989) pp. 294-311.
  19. Wilkes, "Thermal Model of Attic Systems with Radiant Barriers", ORNL/CON-262 91991) Oak Ridge National Laboratory, Oak Ridge, TN/
  20. Kenneth E. Wilkes, "Analysis of Annual Thermal and Moisture Performance of Radiant Barrier Systems", ORNL/CON-319 (1991), Oak Ridge National Laboratory, Oak Ridge, TN.
  21. Wu, "The Effect of Various Attic Venting Devices on the Performance of Radiant Barrier Systems in Hot Arid Climates", Thermal Performance of the Exterior Envelopes of Buildings IV", ASHRAE (1989) pp. 261-270.
  22. Yarbrough, "Assessments of Reflective Insulation for Residential and Commercial Applications", Oak Ridge National Laboratory Report ORNL/TM 8819, Oak Ridge, TN (1983).

- 
23. Yarbrough, "Estimation of the Thermal Resistance of a Series of Reflective Air Spaces Bounded by Parallel Low Emittance Surfaces", Proceedings of the Conference on Fire Safety and Thermal Insulation, S.A. Siddiqui, Editor, (1990) pp. 214-231.
  24. Yarbrough, "Thermal Resistance of Air Ducts with Bubblepack Reflective Insulation", Journal of Thermal Insulation 15 137-152 (1991).
  25. Queer, "Importance of Radiation and Heat Transfer Through Air Spaces", American Society of Heating and Air Conditioning Engineers.

## **Documents**

1993 ASHRAE Handbook Fundamentals - IP Edition, American Society of Heating, Refrigerating and Air-Conditioning Engineers, Inc., 1791 Tullie Circle, NE, Atlanta, GA.

- "Surface Conductances and Resistances for Air" Table 1 - page 22.1
- "Thermal Resistances of Plane Air Spaces" Table 2 - page 22.2
- "Emittance Values of Various Surfaces and Effective Table 3 - page 22.3
- Emittances of Air Spaces"
- "Effective Thermal Resistance of Ventilated Attics" Table 5 - page 22.11

Federal Trade Commission, Part 460, "Labeling and Advertising of Home Insulation"

- |             |               |      |                       |
|-------------|---------------|------|-----------------------|
| Para. 460.5 | R-value Tests | 2(b) | Aluminum Foil systems |
|             |               | 2(c) | Single sheet systems  |
|             |               | 2(d) | Foil facings          |

International Conference of Building Officials (ICBO), "Acceptance Criteria for Reflective Insulation," (1987, revised 1997).

U.S. Department of Energy, "Attic Radiant Barrier Fact Sheet," (1991).

---

## **ASTM Standards**

- C 236-89 “Standard Test Method for Steady-State Thermal Performance of Building Assemblies by Means of a Guarded Hot Box.” 1995 Annual Book of ASTM Standards Vol. 04.06 (1995) pp. 52-62.
- C 727-01 “Standard Practice for Use and Installation of Reflective Insulation in Building Constructions.” 1995 Annual Book of ASTM Standards Vol. 04.06 (1995) pp. 339-341.
- C 976-90 “Standard Test Method for Thermal Performance of Building Assemblies by Means of a Calibrated Hot Box.” 1995 Annual Book of ASTM Standards Vol. 04.06 (1995) pp. 463-481.
- C 1158-01 “Standard Practice for Use and Installation of Radiant Barrier Systems (RBS) in Building Construction.” 1995 Annual Book of ASTM Standards Vol. 04.06 (1995) pp. 655-657.
- C 1224-01 “Standard Specification for Reflective Insulation for Building Applications.” 1995 Annual Book of ASTM Standards Vol. 04.06 (1995) pp. 670-673.
- C 1313-00 “Standard Specification for Sheet Radiant Barriers for Building Construction Applications.” 1996 Annual Book of ASTM Standards Vol. 04.06 (1996) pp.
- C 1340-99 “Standard Practice for Estimation of Heat Gain or Loss Through Ceilings Under Attics Containing Radiant Barriers by Use of a Computer Program.” 1997 Annual Book of ASTM Standards Vol. 04.06 (1997) to be published.
- C 1371-98 “Standard Test Method for Determination of Emittance of Materials Near Room Temperature Using Portable Emisometers.” 1997 Annual Book of ASTM Standards Vol. 04.06 (1997) to be published.
- E 84-01 “Standard Test Method for Surface Burning Characteristics of Building Materials.” 1995 Annual Book of ASTM Standards Vol. 04.07 (1995).
- E 96-00 “Standard Test Method for Water Vapor Transmission of Materials.” 1995 Annual Book of ASTM Standards Vol. 04.06 (1995) pp. 697-704.

---

## APPENDIX A

### INTRODUCTORY COMMENTS ON THERMAL RESISTANCES FOR REFLECTIVE INSULATION SYSTEMS

---

Reflective insulation materials (RIMs) are available in a variety of forms that includes one or more low emittance (emissivity) surfaces. The low emittance surfaces are generally provided by aluminum foils or deposited aluminum surfaces which exhibit very low emittances and high reflectances for long wavelength radiation. The foils are attached to other materials for mechanical strength or support. In some cases, supporting materials add to the thermal resistance of the reflective insulation system that is created upon installation of a reflective insulation in a building or vehicle cavity. The following discussion of thermal resistances will be limited to one-dimensional heat flow across reflective air spaces.

A reflective insulation system (RIS) is formed by a RIM positioned to form one or more enclosed air spaces. A good RIS design will have at least one low-emittance major surface bounding each air space. The purpose of the low-emittance high-reflectance surfaces is to significantly reduce the radiative heat transfer across the enclosed air space. The enclosed air spaces that make up a RIS are not ventilated. There should be no air movement in or out of the enclosed space. The reflective air spaces (enclosed spaces) are positioned so that the major surfaces are perpendicular to the anticipated heat flow direction. When this is done, the thermal resistances of the air spaces in series are additive. If the reflective insulation material has thermal resistance, then this resistance is added to that provided by the reflective air spaces.

The thermal resistance for one-dimensional heat-flow through a series of n reflective air spaces is:

$$R_{\text{TOTAL}} = R_{\text{AIRSPACE ONE}} + R_{\text{AIRSPACE TWO}} + \dots R_{\text{AIRSPACE "n"}} + R_{\text{REFLECTIVE MATERIAL}}$$

Heat is transferred across air spaces by conduction and convection as well as radiation. Convective heat transfer within the air space is related to the movement of air caused by temperature differences. The density of air at constant pressure decreases as the temperature increases. A temperature difference between two regions will result in air density differences which will result in buoyant forces and air movement or natural convection. The magnitude of the buoyant forces increases as the temperature increases and the induced movement of air depends on the buoyant force magnitude and its direction relative to gravity. Since heat flow is in the direction of decreasing temperature, the direction of the buoyant force will depend on the orientation and temperatures of the bounding surfaces. As a result, the convective contribution to the overall heat transfer depends on heat flow direction. Convective heat flow upward is the greatest, and convective heat flow down is the least and can be zero in an idealized system with stagnant air.

Estimates of the thermal resistance of a single reflective air space that has parallel bounding surfaces perpendicular to the direction of heat flow can be made using the following equations.

$$R = (E \cdot h_r + h_c)^{-1} = \frac{\Delta T}{Q} \quad (1)$$



$$E = \left( \frac{1}{\epsilon_1} + \frac{1}{\epsilon_2} - 1 \right)^{-1} \quad (2)$$

$$h_r = 0.00686 \left( \frac{(T_m + 459.7)}{100} \right)^3 \quad (3)$$

$$h_c = f(\ell, T_m, \Delta T, \text{heat flow direction}) \quad (4)$$

$\epsilon_i$	IR emittance for surface "i", i = 1 or 2
E	Effective emittance for an air space
$h_c$	Convective heat transfer coefficient, Btu/ft <sup>2</sup> ·hr·°F
$h_r$	Radiative heat transfer coefficient, Btu/ft <sup>2</sup> ·hr·°F
$\ell$	Thickness of air space, inches
Q	Heat flux, Btu/hr·ft <sup>2</sup>
R	Thermal resistance, ft <sup>2</sup> ·hr·°F/Btu
$T_\mu$	Average of hot and cold surface temperatures, °F
$\Delta T$	Difference between hot and cold surface temperatures, °F

Equation (1) expresses mathematically the fact that R-value depends on heat transfer by radiation,  $E \cdot h_r$ , and heat transfer by conduction-convection,  $h_c$ . The multiplying factor, E, is often called an effective emittance and takes on values between 0 and 1. Its value depends on the emittances of the two major bounding surfaces,  $\epsilon_i$  and  $\epsilon_2$ , as shown by Equation (2). The "E" value for an air space with one low-emittance aluminum boundary is very low, usually in the range 0.03 to 0.05.

Equation (3) is the heat transfer coefficient for radiation,  $h_r$ , between two parallel surfaces. The  $h_r$  is multiplied by "E" to introduce the effect of surface emittances. Equation (2) has been derived for infinite parallel planes and discussed in most texts dealing with radiative heat transfer.

The equation for  $h_c$  is the complication in the R-value calculation. Equation (4) indicates that  $h_c$  depends (is a function of) four variables for one-dimensional heat flow between parallel surfaces. Values for  $h_c$  are developed from experimental data for total heat flow such as that obtained with a hot-box facility such as that described in ASTM C 236. The terms R, E, and  $h_r$  are obtained from emittance and hot-box measurements. Values for  $h_c$  are derived from sets of hot box measurements done for a specific heat-flow direction. Robinson and Powell (see references) have provided  $h_c$  in graphical form and Yarbrough (see references) has provided  $h_c$  in analytical form.

One-dimensional heat flow and R-values between large parallel surfaces held at different temperatures and separated by distance “ $\ell$ ” are established by the above equations and discussion. The procedure has been used to generate the following three tables for single air space R-values for  $T_{\mu} = 50^{\circ}\text{F}$  and  $\Delta T = 30^{\circ}\text{F}$ . These temperatures match the requirements of the FTC labeling rule for “single-sheet” products.

Tables 1, 2, or 3 can be used to estimate the R-value for a RIS provided that the overall temperature difference across each element in the RIS is known. The steady-state temperature difference ( $\Delta T$ ) across each element is related to the R-values of the RIS elements,  $R_i$ , by Equation (5).

$$\Delta T_i = R_i * \frac{\Delta T}{R} \quad (5)$$

$$\Delta T = \sum_i \Delta T_i \quad (6)$$

$$R = \sum_i R_i$$

(7) Unfortunately,  $R_i$  values are related to  $\Delta T_i$ . The only known quantity in Equation (5) is the overall temperature difference  $\Delta T$ . An approach to solving for R is to first estimate the  $\Delta T_i$  values. This should be done in such a way that Equation (6) is satisfied. Given a trial set of  $\Delta T_i$ , the average temperature T in each element can be calculated and  $R_i$  can then be estimated from Tables 1, 2, and 3. This, of course, limits the accuracy since the tables are for  $50^{\circ}\text{F}$ . The total R is calculated by adding the  $R_i$  as indicated by Equation (7). The calculated  $R_i$  are used to recalculate  $\Delta T_i$  by means of Equation (5). This iterative procedure is continued until constant values for  $\Delta T_i$  and  $R_i$  are obtained.

The calculational procedure can be improved by using the iterative procedure and Equation (1) to calculate  $R_i$  values. Table 4 has been prepared to expedite the calculation for a mean air space temperature of  $75^{\circ}\text{F}$ .

Table 1. Calculated R-Values for an Enclosed Air Space at  $50^{\circ}\text{F}$  and  $\Delta T = 30^{\circ}\text{F}$  -- Heat Flow Down

$\ell$	E/	0.030	0.050	0.100	0.150	0.250	0.500	0.750	0.820
0.50		2.63	2.51	2.25	2.04	1.72	1.24	0.97	0.91
0.75		3.72	3.48	3.01	2.64	2.13	1.44	1.08	1.01
1.00		4.69	4.32	3.61	3.10	2.42	1.56	1.15	1.07
1.25		5.57	5.06	4.11	3.46	2.63	1.65	1.20	1.11
1.50		6.36	5.70	4.53	3.75	2.80	1.71	1.23	1.14
1.75		7.03	6.23	4.86	3.98	2.92	1.76	1.25	1.16

2.00	7.60	6.68	5.12	4.15	3.01	1.79	1.27	1.18
2.25	8.08	7.04	5.34	4.29	3.09	1.81	1.28	1.19
2.50	8.49	7.36	5.51	4.41	3.15	1.83	1.29	1.20
3.00	9.15	7.84	5.78	4.58	3.23	1.86	1.31	1.21

Table 2. Calculated R-Values for an Enclosed Air Space at 50°F and  $\Delta T = 30^\circ\text{F}$  -- Heat Flow Horizontal

$\ell$	E/	0.030	0.050	0.100	0.150	0.250	0.500	0.750	0.820
0.50		2.41	2.31	2.09	1.91	1.63	1.19	0.93	0.88
0.75		2.88	2.74	2.43	2.19	1.83	1.29	1.00	0.94
1.00		2.76	2.63	2.35	2.12	1.78	1.27	0.98	0.93
1.25		2.67	2.55	2.28	2.07	1.74	1.25	0.97	0.92
1.50		2.62	2.50	2.25	2.04	1.72	1.24	0.97	0.91
1.75		2.60	2.48	2.23	2.02	1.71	1.23	0.96	0.91
2.00		2.59	2.47	2.22	2.02	1.70	1.23	0.96	0.90
2.25		2.58	2.47	2.22	2.02	1.70	1.23	0.96	0.90
2.50		2.59	2.47	2.22	2.02	1.71	1.23	0.96	0.91
3.00		2.61	2.49	2.24	2.03	1.72	1.23	0.96	0.91

Table 3. Calculated R-Values for an Enclosed Air Space at 50°F and  $\Delta T = 30^\circ\text{F}$  -- Heat Flow Up

$\ell$	E/	0.030	0.050	0.100	0.150	0.250	0.500	0.750	0.820
0.50		1.61	1.56	1.46	1.37	1.22	0.95	0.78	0.75
0.75		1.69	1.64	1.53	1.43	1.27	0.98	0.80	0.76
1.00		1.76	1.70	1.58	1.47	1.30	1.00	0.82	0.78
1.25		1.81	1.75	1.62	1.51	1.33	1.02	0.83	0.79
1.50		1.85	1.79	1.66	1.54	1.35	1.03	0.84	0.79
1.75		1.89	1.83	1.69	1.57	1.37	1.05	0.84	0.80
2.00		1.92	1.86	1.71	1.59	1.39	1.06	0.85	0.81
2.25		1.95	1.88	1.74	1.61	1.40	1.06	0.86	0.81
2.50		1.98	1.91	1.76	1.63	1.42	1.07	0.86	0.82
3.00		2.02	1.95	1.79	1.66	1.44	1.09	0.87	0.82

Table 4. Conduction-Convection Coefficients,  $h_c$ , for use in Equation (1)

Heat Flow Down	Width of Air Space ( $\ell$ , in.)					
	0.5	1.0	1.5	2.0	2.5	3.0
5	0.359	0.184	0.126	0.097	0.080	0.068

10	0.361	0.187	0.129	0.100	0.082	0.072
15	0.363	0.189	0.131	0.101	0.085	0.075
20	0.364	0.190	0.132	0.103	0.087	0.078
25	0.365	0.191	0.133	0.105	0.090	0.081
30	0.366	0.192	0.134	0.106	0.092	0.082

Heat Flow Horizontal

Width of Air Space ( $\ell$ , in.)

DT	0.5	1.0	1.5	2.0	2.5	3.0
5	0.360	0.204	0.169	0.179	0.185	0.189
10	0.366	0.267	0.223	0.233	0.238	0.241
15	0.373	0.247	0.261	0.271	0.275	0.276
20	0.380	0.270	0.292	0.301	0.303	0.303
25	0.387	0.296	0.317	0.325	0.327	0.326
30	0.394	0.319	0.339	0.347	0.347	0.345

Heat Flow Up

Width of Air Space ( $\ell$ , in.)

DT	0.5	1.0	1.5	2.0	2.5	3.0
5	0.381	0.312	0.295	0.284	0.275	0.268
10	0.429	0.381	0.360	0.346	0.336	0.328
15	0.472	0.428	0.405	0.389	0.377	0.368
20	0.511	0.465	0.440	0.423	0.410	0.400
25	0.545	0.496	0.469	0.451	0.437	0.426
30	0.574	0.523	0.494	0.475	0.460	0.449

Example 1. Calculation of Thermal Resistance for a Single Air Space.

Specifications      Surface One:  $T = 70^{\circ}\text{F}$ ,  $\varepsilon_1 = 0.03$   
                              Surface Two:  $T = 80^{\circ}\text{F}$ ,  $\varepsilon_2 = 0.80$   
                              Space between surfaces,  $\ell$ , 2.0 inches  
                              Heat flow down

Equation 2 for E       $E = (1/0.03 + 1/0.8 - 1)^{-1} = 0.0298$   
                               $T_{\mu} = (70 + 80)/2 = 75$   
                               $DT = 80 - 70 = 10$

$h_c$  from Table 4       $h_c = 0.100$   
 $h_r$  from Equation 3       $h_r = 1.049$   
 R from Equation 1       $R = (0.0298 \times 1.049 + 0.100)^{-1} = 7.6 \text{ (ft}^2 \cdot \text{h} \cdot \text{F/Btu)}$

Example 2. Estimation of Thermal Resistance for Two One-inch Reflective Air Spaces in Series.

Specifications:      Air space 1: 1.0 inch wide

---

Side one  $\epsilon_1 = 0.80$

Side two  $\epsilon_2 = 0.03$

Air space 2: 1.0 inch wide

Side one  $\epsilon_1 = 0.03$

Side two  $\epsilon_2 = 0.80$

Cold side temperature 70°F

Warm side temperature 80°F

First Approximation for DT

DT across air space 1:  $DT_1 = 5^\circ\text{F}$

DT across air space 2:  $DT_2 = 5^\circ\text{F}$

Use  $h_c$  at mean temperature 75°F as an approximation.

$T_\mu$  for air space 1: 72.5°F

$T_\mu$  for air space 2: 77.5°F

$E_1 = E_2 = 0.0298$

From Table 4  $hc_1 = 0.184$   
 $hc_2 = 0.184$

From Equation 3  $hr_1 = 1.034$   
 $hr_2 = 1.064$

From Equation 1  $R_1 = 4.66$   
 $R_2 = 4.64$   
 $R = R_1 + R_2 = 9.3$

Check approximation for DT

$DT_1 = 10 \times 4.66/9.3 = 5.01$

$DT_2 = 10 \times 4.64/9.3 = 4.99$

These DT values agree with the assumed values. If the agreement is not satisfactory then the calculation should be repeated using the calculated DT values.

Examples 1 and 2 show the approach used to calculate thermal resistances for an idealized system. A more precise calculation can be carried out with a mathematical expression for  $h_c$  rather than a table. In most cases measured R values are less than those calculated for an idealized system.